

M15S

OPERATION MANUAL



minikol
ITALY

www.minikol.com

Index

1. Operation overview and general introduction.....	1
2. Operation Modes	2
2.1. Manual mode	2
2.2. Single mode.....	3
2.2.1. Setting target value.....	3
2.2.2. Start / Stop / Cancel.....	3
3. Fast Program (10 sets)	5
3.1. Entering preset target values.....	5
3.2. Execute.....	6
4. Select counting direction (+/-).....	7
5. Select Positioning Mode	7
6. Select Speed Mode.....	8
7. Set Retract Distance.....	9
8. Set Conveyer Diameter.....	9
9. Set Pulse/Rev Input from Conveyer.....	10
10. Set software Limit (Hi/Lo End)	10
11. Set Tolerance	11
12. Set Low Speed Limit	12
13. Set Linear Correction	13
14. Enter Parameter Setting Mode.....	14
15. Check Software Version.....	15
16. Load datum values.....	16
16.1. Presetting the real value	16
16.2. Load the real value	16
16.3 Example:.....	17
17. Presetting tool radius – 10 sets.....	18
17.1. Setting the tool radius	18
17.2. Loading a new tool.....	18
17.3. Example for Tool setting:.....	19
17.4. Example to execute	20
18. Fine adjustment	21
19. Check belt speed	22
20. IN/MM Conversion	22
21. Installation Guide	23
21.1. The Magnetic Tape	23
21.2. Installation.....	24
22. Set Device Resolution.....	25
23. Change Counting Direction.....	25

24. Calibration.....	26
25. Power supply & Hardware	27
26. Troubleshooting	28
27.External Dimension.....	30
28. Appendix A -- M15 Specifications.....	31
29. Appendix B -- Parameter.....	32

1. Operation overview and general introduction

1.1 Front panel

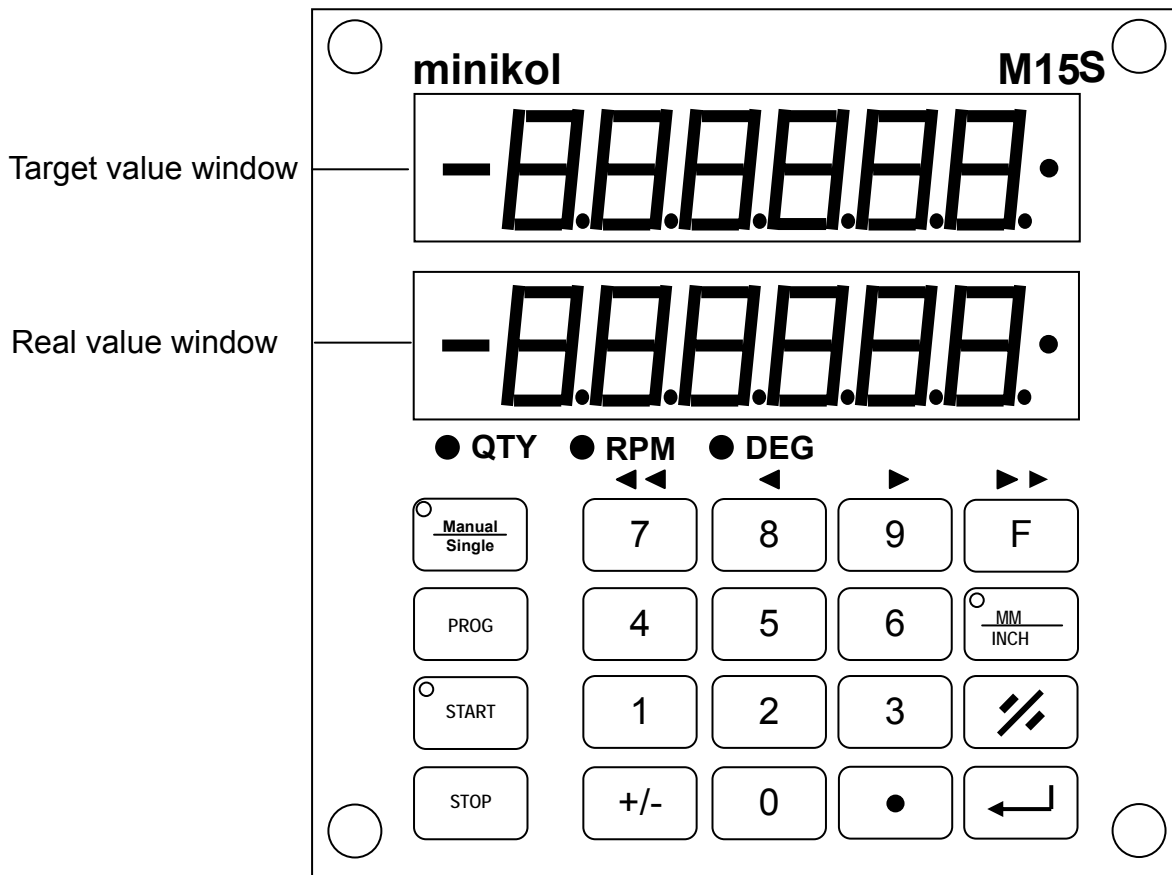

2. Operation Modes

There are two base operating modes – MANUAL and SINGLE.

In MANUAL mode: The operator can move the machine using the M15 keyboard.

In SINGLE mode: Automatic positioning is performed.

Press  to select *Manual mode or Single mode* ◦

☒ When  LED lamp on – Manual mode ;

 LED lamp off – Single mode.

2.1. Manual mode

Keyboard Function :

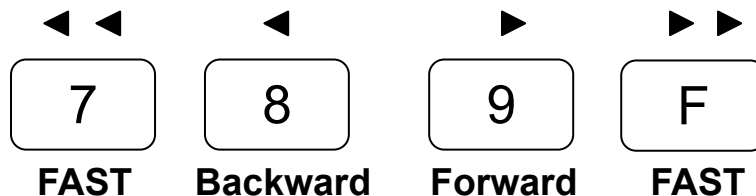

If two-speed positioning mode has been selected, the fast forward and fast backward keys are functional and start fast movement of the machine table.

If one-speed positioning mode has been selected, the fast forward and fast backward keys have the same function as forward and backward keys.

When forward key is pressed, the machine table starts to move in the direction to increase the distance – away from the cutting edge of the tool (machine table goes down).

When backward key is pressed, the machine table starts to move in the direction to decrease the distance – close to the cutting edge of the tool (machine table goes up).

The machine moves until a key is hold pressed. When the key is released, the machine stops.

This mode can be used for manual positioning, or adjusting procedures.

2.2. Single mode

In single mode, the device performs automatic positioning of the machine to the programmed target position.

2.2.1. Setting target value

Step 1 : Press 

(Target window LED starts blinking)

Step 2 : Enter the target value using numerical keypad;

Step 3 : Press  to complete .

※  LED lamp starts blinking – the device is ready to start the positioning .

2.2.2. Start / Stop / Cancel

Press  to start the positioning. The LED lamps now stops blinking and remains on during the procedure.



Press  to cancel the positioning. The LED lamp is turned off.

If the  key is pressed when the positioning is already running, the procedure is interrupted, the machine is stopped,

and the  LED is turned off. To repeat the positioning of the

same target, press   .

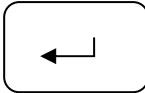
To program another target value press

 – enter new value –  

2.3. Example :

Assume:

actual target value on display = 100.00mm;

actual real value on display = 100.00mm

To change the target value to 20.25mm

Step 1 : Press **PROG** → the LED lamp on Target window is blinking.

Display	1 0 0.0 0 	Target value
	1 0 0.0 0	Current value

Step 2 : Enter new target value Exp : 20.25mm

Press **2** **0** **.** **2** **5**

Display	2 0.2 5 	Target value
	1 0 0.0 0	Current value

Step 3 : Press  to complete .

※ The  **START** LED lamp is blinking – ready for positioning.

Press  **START** to start the positioning or press **STOP** to cancel.

3. Fast Program (10 sets)

To facilitate frequently used positions, the keys 0 to 9 have associated preset target values. By pressing one of these keys, its target value is loaded automatically, and the positioning can be started immediately.

3.1. Entering preset target values

Step 1: Press    

Step 2: Select a key 0-9 (total of 10 values).





Step 3: Enter the target value.

Step 4: Press  to confirm

※ Follow the same procedure for other program setting;

Press  to exit.

3.1.1. Example : Program 0 = 10.00mm ; Program 1 = 20.00mm .

Step 1: Press    

Display



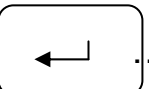

P r o G	—	
		

Step 2: Press  【select preset value 0】

Step 3: Press   【enter value】

Step 4: Press  【complete】

Step 5: Press  【select preset value 1】

- Step 6: Press   【enter value】
- Step 7: Press  【complete】
- Step 8: Press  to exit

3.2. Execute

Step1: Enter single mode,  LED lamp is off.

Step2: Press a key 0-9

※  LED lamp is blinking -> ready for start .

3.3. Example: Program# 0 = 10.00mm, Program# 1: 20.00mm

Step 1: In Single mode,  LED lamp is off.

Step 2: Press  【program# 0】

Now you will see the preset value: 10.00mm (program# 0)

 LED lamp is blinking, complete.

Press  to begin positioning.

4. Select counting direction (+/-)

You can select the counting direction according to the machine movement.

Step 1: Press   

Display  **【default】**

Step 2: Press  to change the direction, "-dir" for left or "dir- "
for right.

Step 3: Press  to confirm or press  to clear.

5. Select Positioning Mode

Step 1: Press   

Step 2: Press  to select:

- a. ---||--- both directions
- b. ---| left
- c. |--- right

Step 3: Press  to confirm or press  to clear.

6. Select Speed Mode

With this function, you can enter 1 speed mode or 2 speed mode.

Step 1: Press   

Display 
 **【default】**

Step 2:  to switch between 1 or 2 speed.

Step 3: Press  to confirm or press  to clear.

7. Set Retract Distance

In some cutting application, you can retract the machine with a specified distance.

Step 1: Press   

Display

r E t r
5.00

Step 2: Enter the value (Min. = 0.01 , Max. = 20)

Step 3: Press  to confirm or press  to clear.

8. Set Conveyor Diameter

For M15 to calculate the real speed, please enter the conveyor diameter according to each machine.

To set conveyor diameter, you can:

Step 1: Press   

Display

d i A
50.00

 **【default】**

Step 2: Enter the value (Min. = 30)

Step 3: Press  to confirm or press  to clear.

9. Set Pulse/Rev Input from Conveyor

Get the real belt speed (M/min), please enter the pulse / rev input from conveyor according to each machine.

To set the PPR of conveyor.

Step 1: Press

Display
 【default】

Step 2: Enter the value (PPR) to the real value window.

Step 3: Press to confirm or press to clear.

10. Set software Limit (Hi/Lo End)

There are High and Low software limit

a. To set the Lo_End





Press

b. To set the High_End

Press

11. Set Tolerance

The tolerance defines the accuracy of the positioning.

Step 1: Press    

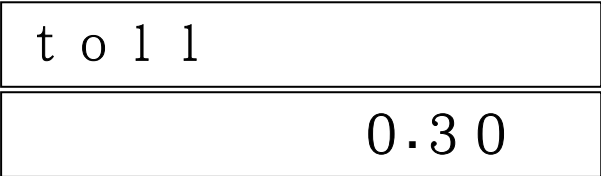
Display  **【default】**

Step2: Enter the value for tolerance.

Step 3: Press  to confirm or press  to clear.

12. Set Low Speed Limit

This function defines the speed level which is considered abnormal for the machine.

When M15 starts the movement in any direction, and the machine does not move, or moves with a speed lower than defined, it stops the machine and displays:

E n G i n E
F A u l t

Press  to clear.

To set low speed limit:

Step 1: Press    

Display

F A u l t
5 5

Step 2: Please enter the low speed level 0~99.

0 => Machine test is disabled.

1 => very low



:

:

99 => high;

Step 3: Press  to confirm or press  to clear.

13. Set Linear Correction

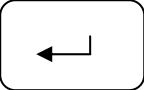
Step 1: Press    

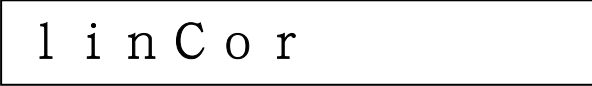
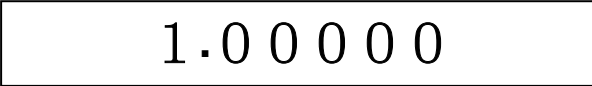
Display 

Step 2: Please enter the value between 0.0001~9.9999



Step 3: Press  to confirm or press  to clear.

14. Enter Parameter Setting Mode

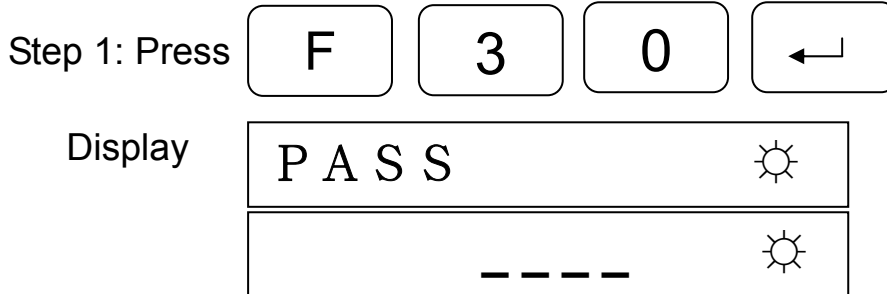
With this function you can select each parameter to be locked or unlocked. When a parameter is locked, then the enduser can only see the value, but can not change it.



Step 2: Enter the password.

Step 3: Use   key to scroll the parameters up or down



Step 4: Press  to lock or unlock

┌ On => unlock
└ Off => lock

Step 5: Press  to confirm or press  to clear.

15. Check Software Version

To check the released version of M15, you can:

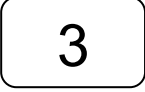
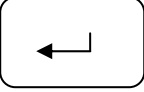
Step 1: Press    

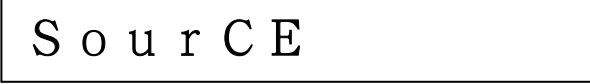
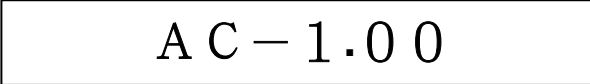
Display 

In the real value window, you will see the released version.

Step 2: Press  to confirm or press  to clear.

16. Load datum values

The real position in the device is referred to the distance between the machine table and the cutting edge of the tool – in other words, the cutting edge of the tool defines the zero point of the machine. It is, however, difficult, or impossible to move the machine table to this point. Therefore, a simple procedure is used to lock the table position to the zero:

- the machine is positioned roughly (for example using MANUAL mode)
- a piece of material is worked
- the thickness of the worked material is measured
- the value obtained is preset as real value into the device

It may be necessary to repeat the above procedure periodically, as the tool wears off, or after the tool replacement.

16.1. Presetting the real value

Step 1:   



Step 2: enter the value.

Step 3: Press 

16.2. Load the real value

Step1: Press   

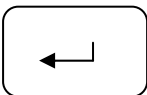
Display 

press  to confirm or press  to cancel.





16.3 Example:

The current value is 10.00mm but the actual length is 10.50mm.

Step 1: Press   

Display

O r i G i n	
0.00	

Step 2: Press    

Step 3: Press 

Step 4: Press   

17. Presetting tool radius – 10 sets

This function allows the operator to use up to 10 different tools on the same machine without the need to adjust the real value after tool change. Different tools normally have different radiuses. The effect of this is the zero point of the machine is shifted. By presetting the tool radius, this shift is performed automatically on loading the tool.

Explanation:

The current value: 100.00mm

Radius of Tool is 20.00mm

- then the current value will be 80.00mm

17.1. Setting the tool radius

Step 1: Press   

Step 2: Select the tool code (1 ~ 9; 0: 0.00mm -- default)

Step 3: enter the tool radius

Step 4: Press 

※ Press  to exit ◦

Tool code "0" selects tool radius = 0

17.2. Loading a new tool

Step 1: Press   

Step 2: Select the tool code (0 ~ 9)

Step 3: Press  ◦

17.3. Example for Tool setting:

Tool# 1 =10mm; Tool# 2 = 20mm .

Step 1: Press   

Display

O F F S	—	
		

Step 2: Press  【select the tool# 1】

Step 3: Press   【input the tool radius】

Step 4: Press  【complete】

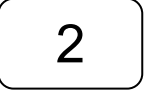
Step 5: Press  【select the tool#: 2】

Step 6: Press   【enter the tool radius】

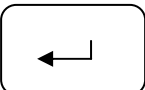
Step 7: Press  【complete】

※ You can follow the same procedure for other sets;

Press  to clear.

17.4. Example to execute

Call the tool#: 2 (the tool radius is 20mm) .

Step 1: Press

Display

L O A d	0	☀
	0.00	☀



Step 2: Press 【Select the tool#: 2】

Step 3: Press 【complete】

18. Fine adjustment

※ Only in single mode -  LED lamp is off.

To set the step for fine adjustment.

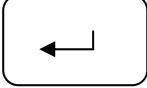
Step 1: Press    

Display

S t E P
1 . 0 0

..... 【default】

Step 2: Enter the value.

Step 3: Press  to confirm or press  to clear.

Preset value: 1.00mm, The min. value : 0.05mm

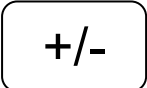
Press  once, the target value will increase by 1.00mm;

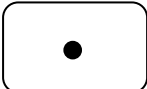
Press  once, the target value decrease by 1.00mm ;

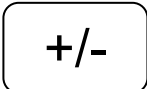
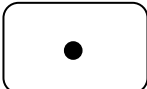
※ When you press  or  ,

 LED lamp will blink → waiting for start.

19. Check belt speed

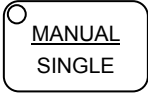
※ In single mode -  LED lamp is off.

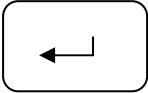
Press  once .

The PRM LED lamp turns on and the target window will show the belt speed.

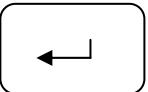
Press  to exit .

20. IN/MM Conversion

The dedicated MM/INCH key allows for immediate switch of the units between millimeters and inches. The LEDs on the key indicate the selected unit. Switching between MM and INCHES has no effect on the control functions.

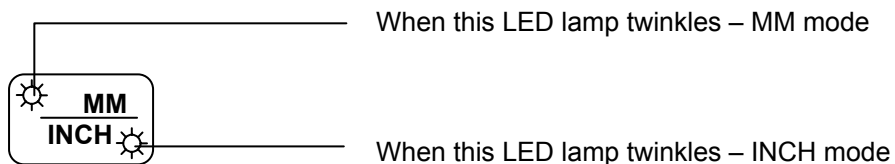

21. Installation Guide

21.1. The Magnetic Tape

The magnetic tape consists of three components:

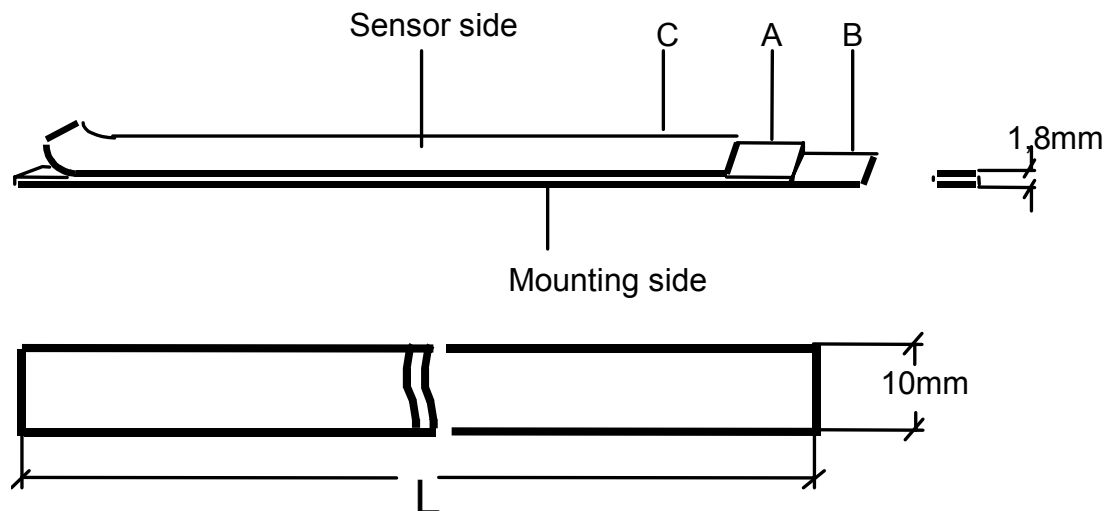

A. A magnetized, highly flexible synthetic tape.

B. Flexible steel tape. A and B are already factory-bonded.

C. To keep the flexibility for transport and installation, the third part, also a steel tape is delivered separately. It serves for mechanical protection of the synthetic tape and must be stuck on the magnetic synthetic tape after installation.

Installation:

- A. Must be away from inductive and capacitive interference source as conductor, relays, engines, switch power pack clocked controllers, etc.
- B. Must be wired separately from heavy-duty current wires.
- C. Must be kept a distance to interference sources.

21.2. Installation

- A. Ensure to apply tape on clean, dry and plain surface.
- B. For the best adhesion, please apply the tape with ambient temperature: 21~38 .
- C. We recommend to make a chamfer on the machine to install the tape.

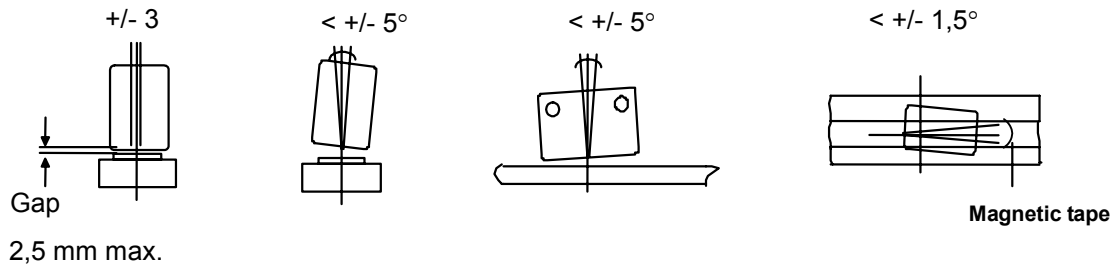





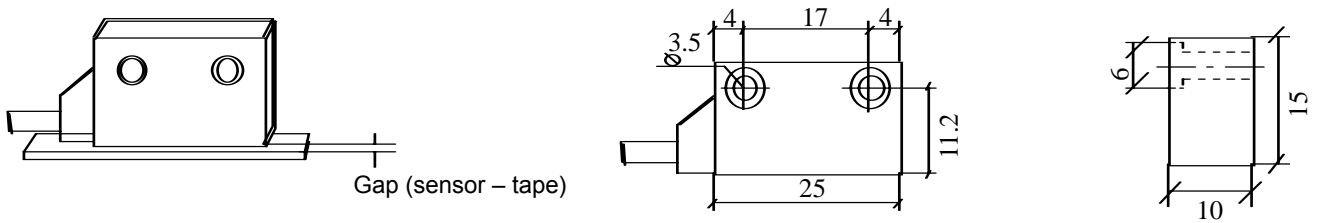



Recommend Gap between tape and sensor: 1mm

Unit: mm

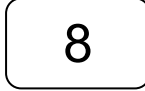
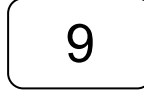

22. Set Device Resolution

Step 1: Press    

Step 2: Use     
   

to select resolution

Step 3: Press  to confirm or press  to clear.

23. Change Counting Direction

Step 1: Press   







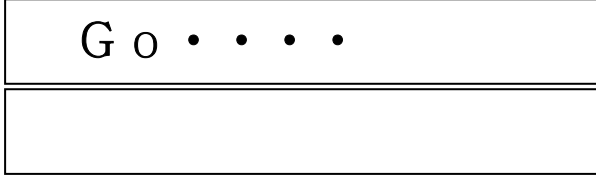

Step 2: Press  to change the direction

Step 3: Press  to confirm or press  to clear.

24. Calibration

Step 1: Press    

Display 

Step2: Use          to move the machine until M15 terminates the calibration and restarts.

25. Power supply & Hardware

a. Power supply: DC18 ~30V 50mA, 2 pin connector

b. Battery: C type battery x 1,
the battery life : 2.5 year (24hr)

c. Output (8 pin connector)

- Relay × 4: Forward, Reverse, low speed and positioning.

※Positioning: only works inside the tolerance and on position mode.

(Manual mode: do not work)

- NO
- AC240V/ 5A AC120V/ 10A DC24V/ 10A

d. Input (5 pin connector)

- COM
- start
- stop
- repeat
- No use

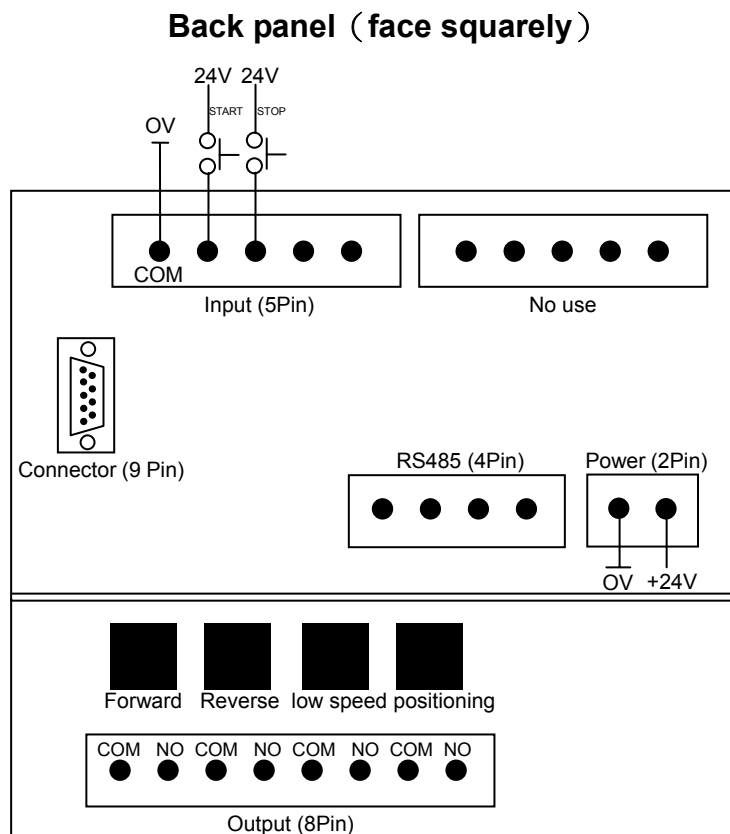

26. Troubleshooting

26.1 Display



"Change RST" message appears when M15 detects a motion in the wrong direction.

For example: M15 switches the outputs to move forward, but the bed starts moving in the reverse direction.

Usually this is caused by the wrong wiring of the three phase motor.

Press  to clear.

Check the wiring and change if necessary.

26.2 Display

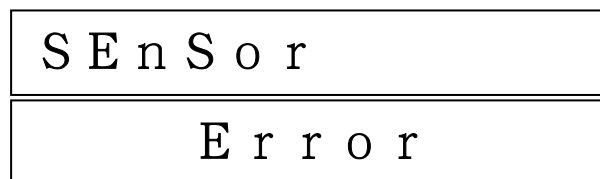

Possible cause:

- no sensor,
- 9 Pin connector is loosen,
- wire broken or
- the gap is too big between sensor and tape;

Excluding : Check the sensor, sensor cable and sensor connector.

26.3 Display

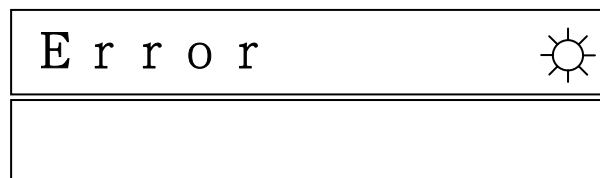

Possible cause: Incorrect operation.

Excluding : Press  to clear ◦

26.4 Display



This message appears after power-on and indicates battery discharged. The battery **MUST** be changed to resume the operation of the device.

The battery can be changed like this:

- With power-on, change the battery. Then turn the power off, wait several seconds, and turn the power on again. The device will resume the normal operation.
- Turn the power off. Be careful not to move the machine during power-off. Replace the battery and turn the power on. The device will resume the normal operation

27. External Dimension

Unit: mm

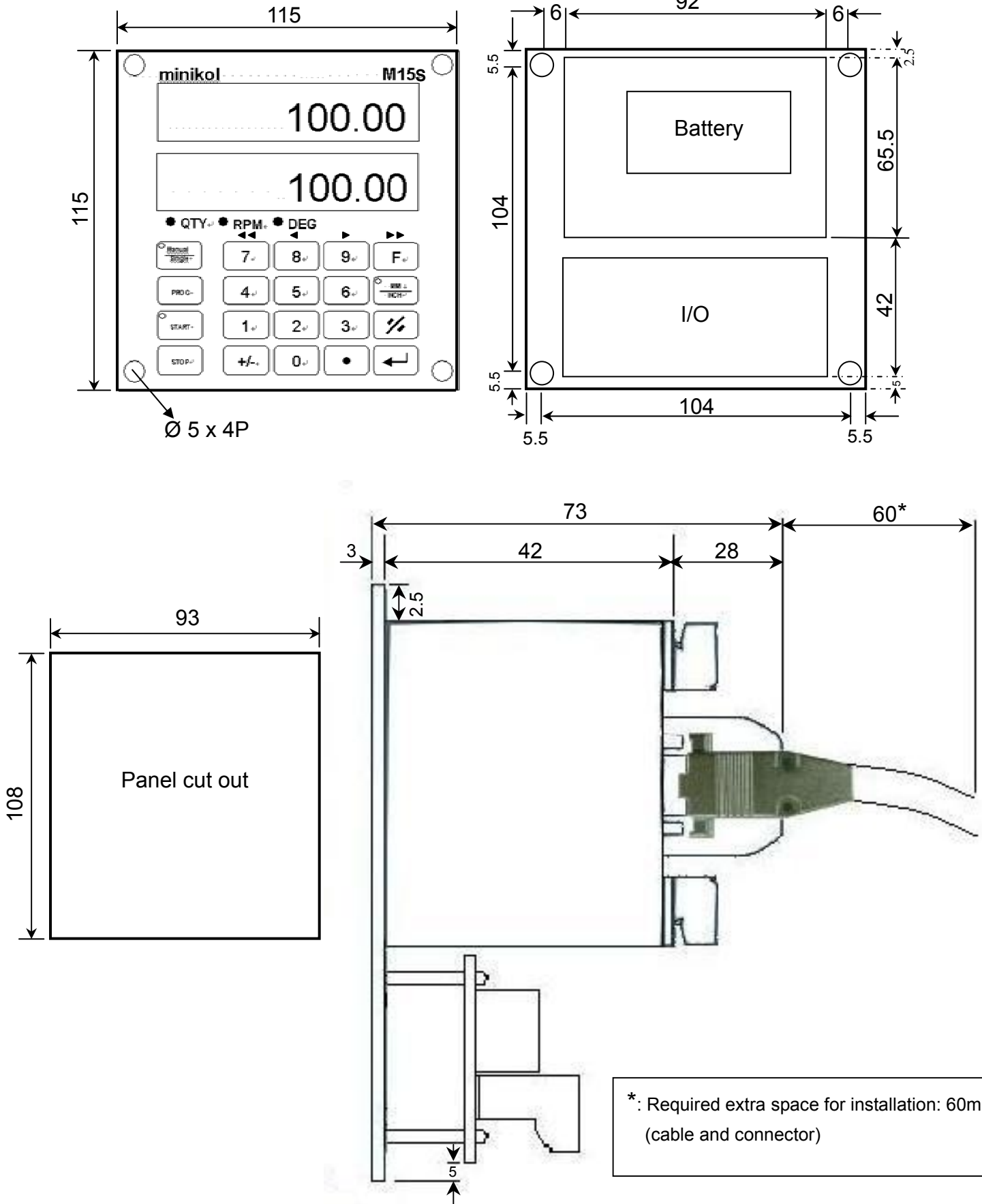

*: Required extra space for installation: 60mm (cable and connector)

28. Appendix A -- M15 Specifications

Feature	Technical data	Additional information
Housing	115w × 115h × 73d (mm)	
Panel cut out	93w × 108h (mm)	
Mounting screws	M3 × 4	104 × 104 (mm)
Supply voltage	24 VDC 50mA	C type battery × 1
Battery voltage control	Yes	Low power alarm via display
Sensor cable length	Standard: 3m	Option: 0.5m, 1.5m
Coefficient of expansion	$\alpha = 16 \times 10^{-6} \times 1/K$	
Gap sensor/strip	max. 2.5mm	
Display	15mm LED × 6 digits × 2 line	
Output	4 digital output	AC250V / 7A AC110V/7A DC24V/10A
Input	4 digital input	24VDC
Operating elements	20 button keyboard	
Test mark/interfer. Protection class		3 accord. to IEC 801
Travel speed	1.5m/s	
System accuracy	$\pm (0.025+0.02L)$ mm L: Meter	
Repeatability	0.01mm	
Temperature range	Working temperature 0+ 50°C	storage temperature -20+70°C
Humidity	max. 95% rF	Condensation not permitted

29. Appendix B -- Parameter

Parameter	Display	Description	Default	Remarks
0	CHAnGE	Load datum value	0	
1	dir	Select counting direction (+ / -)	-dir	
2	OriGin	Load origin	0.00mm	
3	OffS-	Set tool diameter	0.00mm	
4	POSdir	Positioning mode	-- --	
5	SPEEd	One or two speed positioning	1sp	
6	rEtr	Retract distance	5.00mm	
7	diA	Conveyer diameter	50.00mm	
8	PPr	Pulse/rev input from conveyer	4	
9	LOAd 0	Load tool diameter	0.00	
10	Lo-End	- Software limit	-50.00mm	
11	Hi-End	+ Software limit	1000.00mm	
17	tOLL	Tolerance	0.30mm	
18	StEP	Fine adjustment distance	1.00mm	
19	FAuLt	Low speed limit	55	
20	LinCOR	Linear correction	1.00000	
30	PASS	Parameter lock	----	
33	SOurCE	Software version		
55	PrOG-	Fast program		
90	rES	Resolution	0.01mm	
99	GO....	Sensor calibration	No default Value	